

Installation kits

for position indicators used on linear actuators
GN 491 / GN 492

SPECIFICATION

Identification no.

- No. **1**: for mechanical position indicators DD52R / DD51 / DD50
- No. **2**: for electrical position indicators DD52R-E / DD51-E

Adaptor shaft

Steel

blackened

Torque support

Aluminium

black anodized

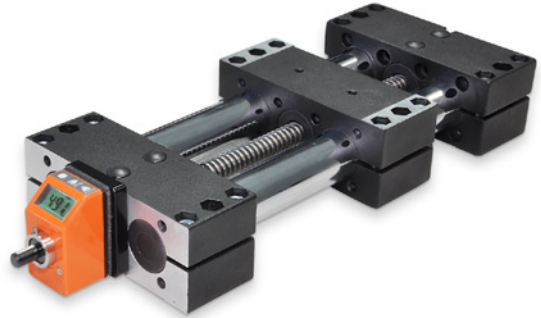

INFORMATION

The installation kits GN 491.1 are required for the attachment of a position indicator to double tube linear actuators. They consist of an adapter shaft and, depending on the position indicator, a torque support including fixing screws.

Mechanical position indicators DD52R (see page 726) / DD51 (see page 718) / DD50 (see page 716) must be ordered so that the counter is aligned with the rising of the trapezoidal thread spindle.

For the position indicators DD52R-E (see page 726) / DD51-E (see page 722) the respective rising is set at the position indicator for every programming.

ACCESSORY

Position indicators and handwheels have to be ordered separately.

TECHNICAL INFORMATION

- ISO-Fundamental tolerances (see page A21)

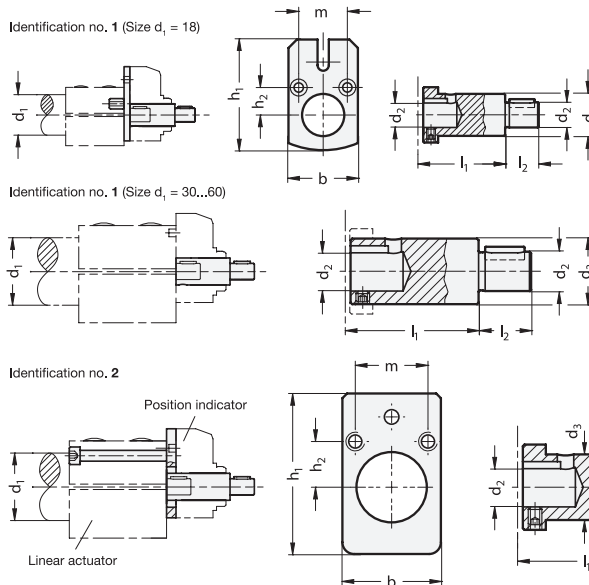

GN 491.1

Description	d1 Ø Linear actuator	d2 f7	b	d3	l1	l2	h1	h2	m	For position indicator	⚖
GN 491.1-18-6-1	18	6	27	10	30	16	38.5	10	20	DD50	90
GN 491.1-30-8-1	30	8	40	14	35	15	54.5	15	30	DD51	100
GN 491.1-40-12-1	40	12	50	20	39	16	72.5	19.5	39	DD52R	159
GN 491.1-50-12-1	50	12	60	20	39	17	72.5	23	46	DD52R	159
GN 491.1-60-14-1	60	14	70	20	39	18	72.5	27.5	55	DD52R	92
GN 491.1-30-8-2	30	8	40	14	44	15	54.5	15	30	DD51-E	150
GN 491.1-40-12-2	40	12	50	20	51	16	72.5	19.5	39	DD52R-E	247
GN 491.1-50-12-2	50	12	60	20	51	17	72.5	23	46	DD52R-E	271
GN 491.1-60-14-2	60	14	70	20	51	18	72.5	27.5	55	DD52R-E	324

